

ICE BUILDER PIB 8-13

Application

Ice water has been used for many years in (large) dairy farms and in collection centres because it can cool large amounts of milk in a very short time. A **lot of ice** can be stored on a small area, which results in a compact space saving unit. Thanks to this **large ice reserve**, a **huge amount of ice water (0.5-1 °C)** can be produced. In combination with robotic milking there is **no risk of freezing** even for the smallest quantities of milk.

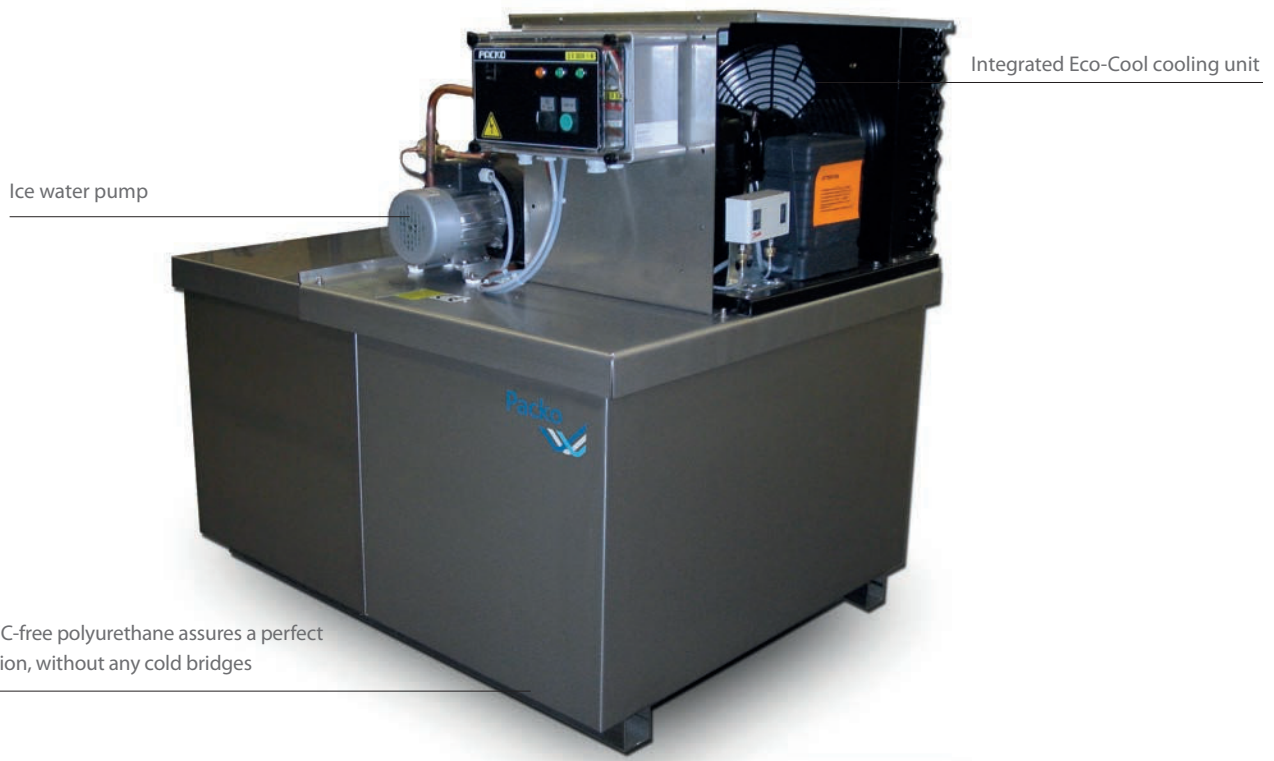

Construction

- Construction completely made in stainless steel 18/10 – AISI 304
- Insulated with polyurethane foam for an excellent insulation and extra strength of the tank
- The well dimensioned evaporator enables the storage of a large ice reserve, this guarantees a maximum cold transfer.
- The evaporator is made of seamless copper tubes and mounted in a stainless steel frame for a long lifetime.

Operation

- Accumulation of energy at cheaper electricity rates via e.g. night rate or alternative energy such as solar panels
- An ice thickness probe (ice accumulation up to 100% ice thickness) activates the Eco-cool cooling unit until an equal layer of ice on all evaporator tubes has been built
- The water in the ice builder is cooled to 0.5°C.
- A pump sends the ice water to the milk cooling tank or a pre-cooler to cool down the milk
- The ice is melted down by the warm water returning from the consumer

Important options

- Anti-frost protection
- Other type of ice water pump
- Time clock for use of night rate - only if not in combination with a milk cooling tank with iControl

DIMENSIONS

PIB 8-13

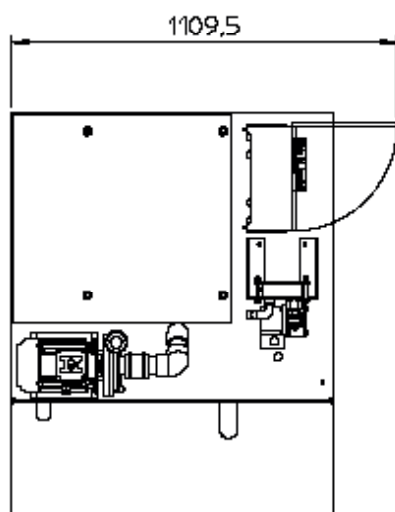
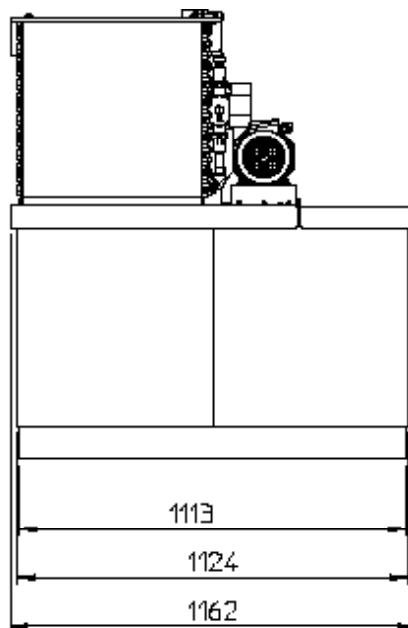
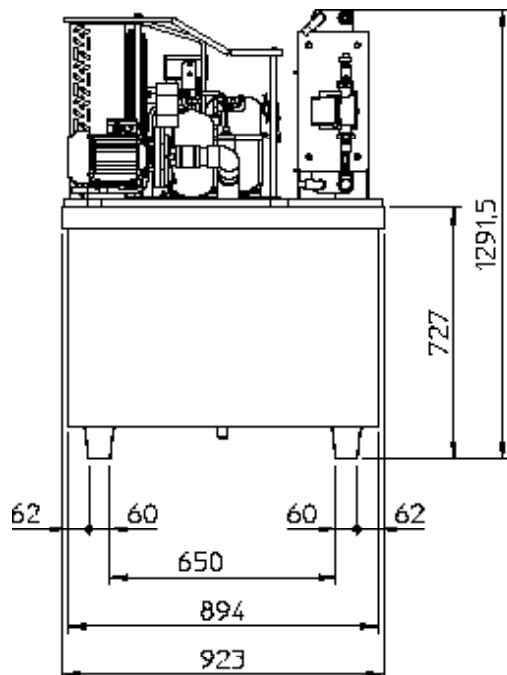

Model PIB	Energy storage		Amount of ice kg	Amount of water litres	Weight kg
	kWh	kcal			
8	8.8	7570	95	396	320
13	13.4	11488	144	396	370

Fullwood Packo nv

Torhoutesteenweg 154 - 8210 Zedelgem - Belgium
 T +32 50 25 06 10 - E cooling@fullwoodpacko.com
www.packocooling.com